

KATALOG 2002.

PROIZVODNI PROGRAM

REŠETKE	5 - 16
LINIJSKI DIFUZORI	17 - 19
ANEMOSTATI	20 - 41
OP. STROPOVI	42 - 43
PRIGUŠIVAČI ZVUKA	44 - 46
FILTERI	47 - 52
ŽALUZIJE	53 - 56
VENTILATORI	57 - 61
KLIMA KOMORE	63 - 66
VISEĆI GRIJAČI	67 - 72
DIJAGRAMI	73 - 106

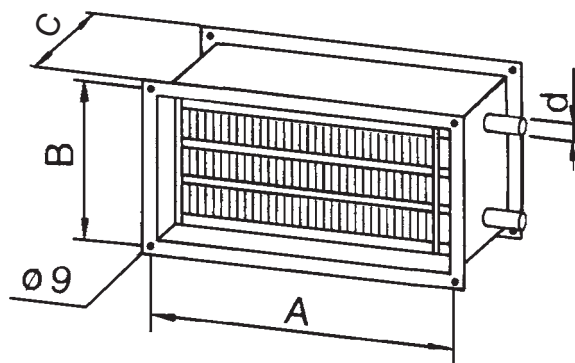
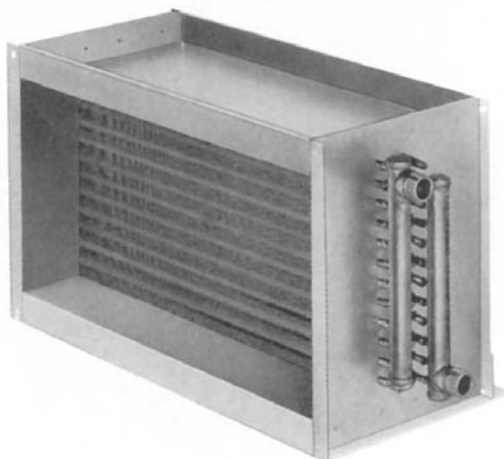

TIP	kW	m ³ h	A	B	C	d
TGK 10	6	600	310	280	250	1
TGK 12	17	1300	440	410	250	1
TGK 22	36	3000	570	540	250	5/4
TGK 32	58	4400	740	710	250	1 1/2
TGK 42	103	8500	870	840	250	1 1/2

Snaga grijača odnosi se na ulaznu temp. 70/90°C i max. protok zraka prema tablici.

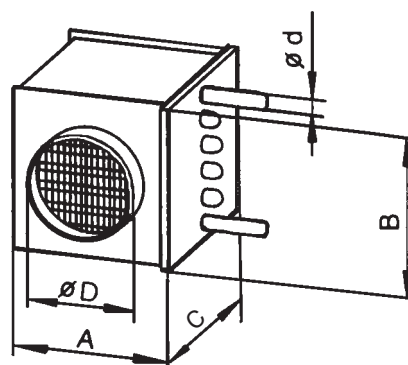
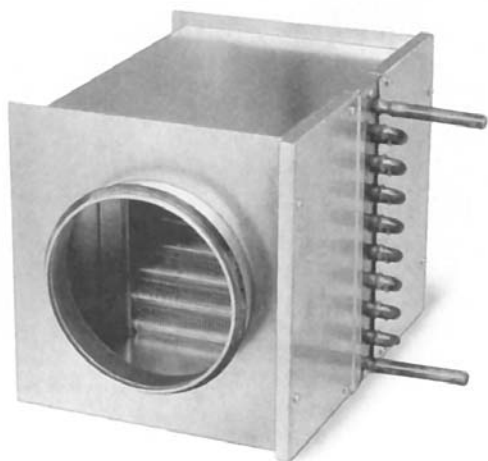

TIP	kW	m ³ h	A	B	C	D	d
TGO 10	6	600	350	320	180	250	1
TGO 12	17	1300	480	450	180	350	1
TGO 22	36	3000	610	580	180	400	5/4
TGO 32	58	4400	780	750	180	550	1 1/2
TGO 42	103	8500	910	880	180	650	1 1/2

Snaga grijača odnosi se na ulaznu temp. 70/90°C i max. protok zraka prema tablici.



Viseći grijač **TVG** namjenjen je za zagrijavanje prostorija svih veličina i namjena (kancelarije - proizvodne hale). Izrađuje se u dvije verzije: **TVG** - kao toplovodni grijač, **TEG** - elektrogrijač.

Učinak **TVG**-a kreće se kod tople vode 90-70°C od 8000 Kcal/h do 86000 Kcal/h. Izmjenjivač topline izrađen je od aluminijskih lamela i bakrenih cijevi. Elektro motor je trobrzinski s termičkom zaštitom.

TVG	A □	c	d
12	460	440	300
22	590	570	300
32	760	740	400
42	890	870	400

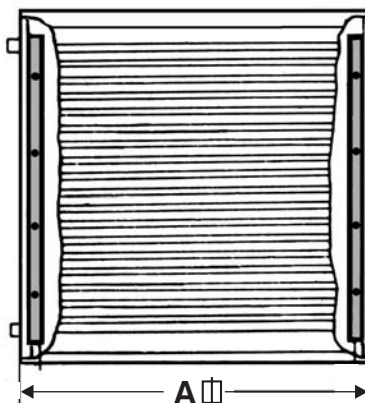
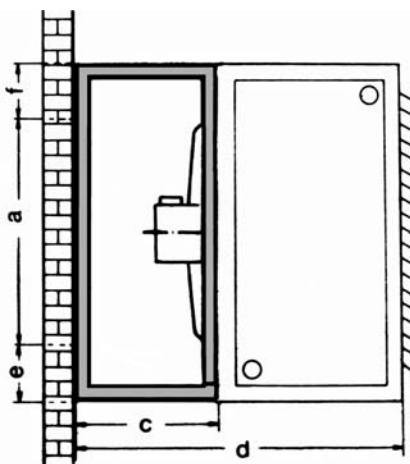

TIP GRIJAČA	TVG - 12/3						TVG - 22/3					
Br. o/min.	1400		1000		700		1400		1000		700	
L (m ³ /h)	1300		800		560		3000		1800		1200	
UČINAK	Kcal/h	IT	Kcal/h	IT	Kcal/h	IT	Kcal/h	IT	Kcal/h	IT	Kcal/h	IT
	14000	37	12000	46	10000	53	30000	30	25000	39	20000	47

TIP GRIJAČA	TVG - 32/3						TVG - 42/3					
Br. o/min.	950		670		470		950		670		470	
L (m ³ /h)	4400		3100		1900		8500		6000		3200	
UČINAK	Kcal/h	IT	Kcal/h	IT	Kcal/h	IT	Kcal/h	IT	Kcal/h	IT	Kcal/h	IT
	48000	37	42000	39	36000	50	86000	29	65000	34	47000	46

PRIKLJUČNI ELEMENTI NA TLAČNOJ STRANI:

ISTRUJNA MLAZNICA P-10

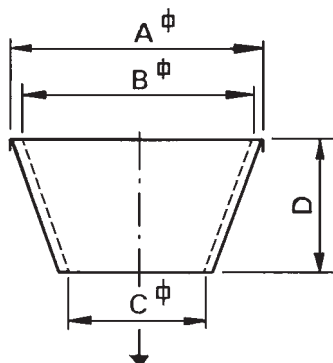

TIP	A	B	C	D
P-10/12	460	420	200	200
P-10/22	590	550	300	240
P-10/32	760	720	370	280
P-10/42	890	850	500	300

ISTRUJNA MLAZNICA P-11

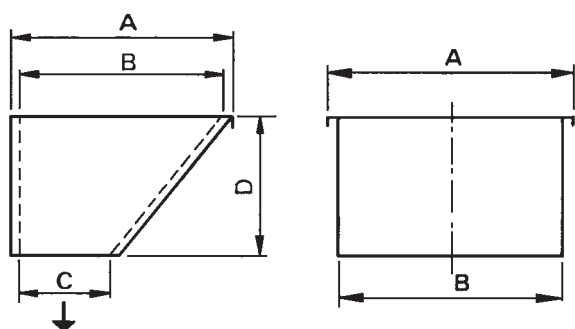

TIP	A	B	C	D
P-11/12	460	420	125	290
P-11/22	590	550	220	340
P-11/32	760	720	240	400
P-11/42	890	850	350	440

DVOSTRANI ISTRUJNI PRIKLJUČAK P-20

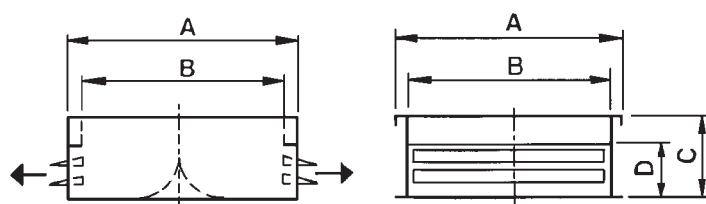

TIP	A	B	C	D
P-20/12	460	420	130	80
P-20/22	590	550	170	120
P-20/32	760	720	195	135
P-20/42	890	850	260	200

PRIKLJUČNI ELEMENTI NA USISNOJ STRANI:

VANJSKA FIKSNA ŽALUZIJA P-30

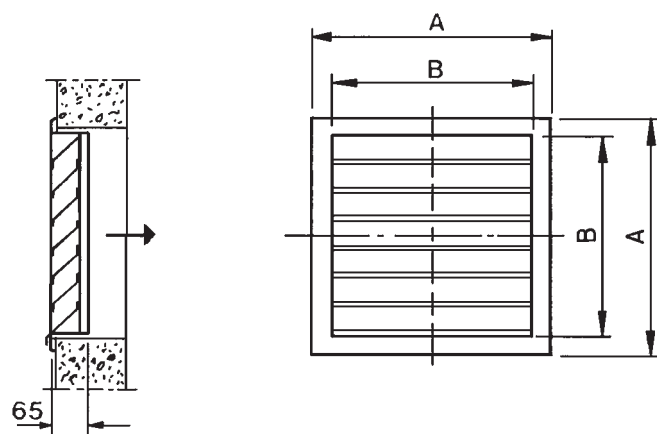

TIP	A	B
P-30/12	510	410
P-30/22	640	540
P-30/32	810	710
P-30/42	940	840

KOMORA ZA MIJEŠANJE ZRAKA P-40

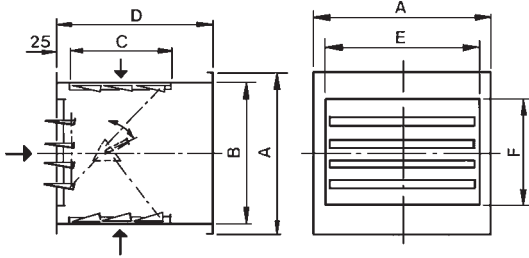

TIP	A	B	C	D	E	F
P-40/12	460	420	280	400	360	280
P-40/22	590	550	300	440	490	402
P-40/32	760	720	340	480	660	563
P-40/42	890	850	375	520	790	653

KOMORA ZA MIJEŠANJE ZRAKA P-41

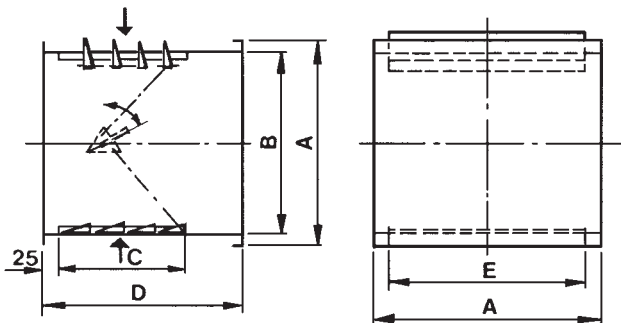

TIP	A	B	C	D	E
P-41/12	460	420	280	400	360
P-41/22	590	550	300	440	490
P-41/32	760	720	340	480	660
P-41/42	890	850	375	520	790

PRIKLJUČNA KOMORA P-50

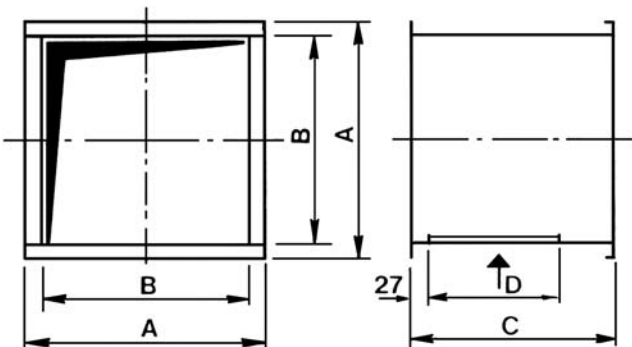

TIP	A	B	C	D
P-50/12	460	420	400	280
P-50/22	590	550	440	300
P-50/32	760	720	480	340
P-50/42	890	850	520	375

ZIDNA KOMORA P-60

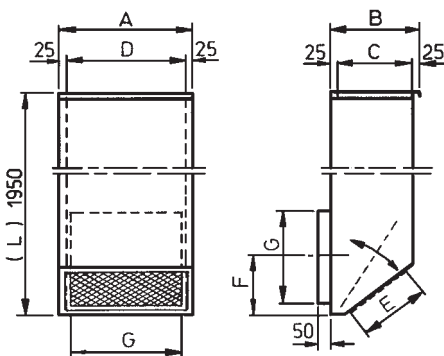

TIP	A	B	C	D	E	F	G	L min.
P-60/12	460	320	280	420	280	230	420	220
P-60/22	590	340	300	550	300	295	550	230
P-60/32	760	380	340	720	350	380	720	250
P-60/42	890	415	375	850	390	445	850	270

ZIDNA KOMORA P-61

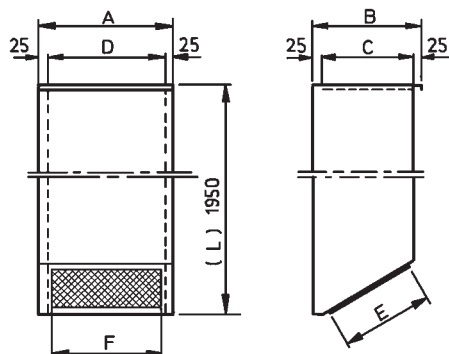

TIP	A	B	C	D	E	F	L _{min.}
P-61/12	460	320	280	420	280	360	220
P-61/22	590	340	300	550	300	490	230
P-61/32	760	380	340	720	350	660	250
P-61/42	890	415	375	850	390	790	270

ZIDNA KOMORA P-62

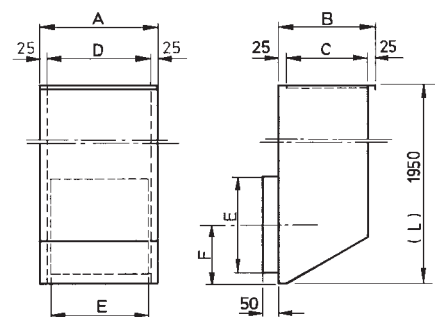

TIP	A	B	C	D	E	F	L _{min.}
P-62/12	460	320	280	420	420	230	450
P-62/22	590	340	300	550	550	295	580
P-62/32	760	380	340	720	720	380	750
P-62/42	890	415	375	850	850	445	880

FILTER P-70

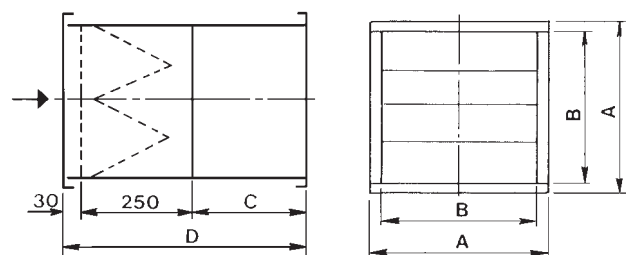

TIP	A	B	C	D
P-70/12	460	420	230	510
P-70/22	590	550	230	510
P-70/32	760	720	255	535
P-70/42	890	850	270	550

ELASTIČNA SPOJNICA P-70

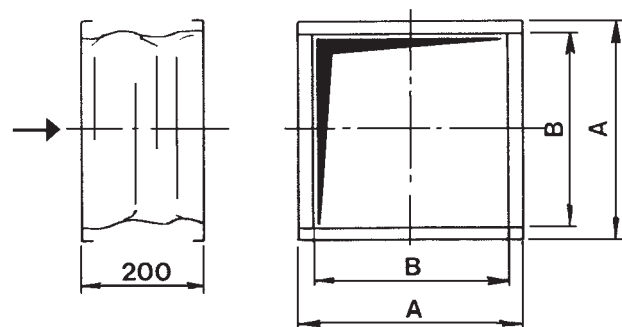

TIP	A	B
P-80/12	460	420
P-80/22	590	550
P-80/32	760	720
P-80/42	890	850

KROVNA KAPA P-90

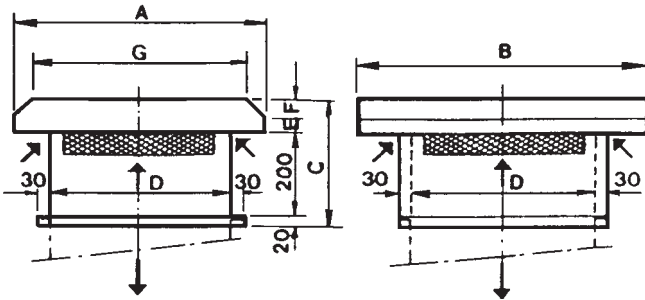

TIP	A	B	C	D	E	F	G
P-90/12	580	650	320	420	40	60	460
P-90/22	770	800	350	550	55	75	620
P-90/32	1020	1100	390	720	70	100	820
P-90/42	1210	1250	420	850	85	115	980

KROVNA KAPA P-91

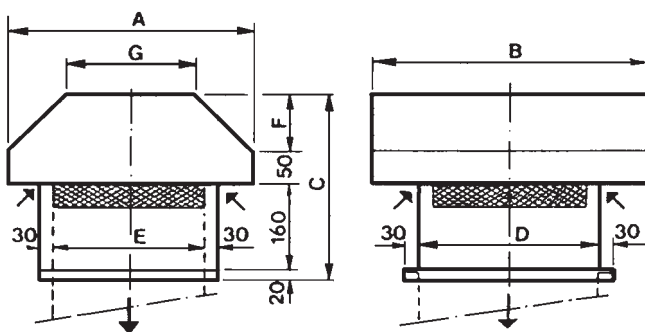

TIP	A	B	C	D	E	F	G
P-91/12	570	500	330	420	280	100	250
P-91/22	700	550	340	550	300	110	250
P-91/32	870	600	350	720	340	120	250
P-91/42	1000	700	380	850	375	150	300